



ZP730-2

Analogue optical smoke sensor

Reliable sensing for most fire alarm applications

Designed for early response to slow burning, smoldering fires, the ZP730-2 is an analogue smoke sensor, developed to provide reliable sensing for most fire alarm applications. The sensors proven stability in air movement associated with air conditioning systems has made it a popular selection for modern building interiors. Operating on light scatter principles, the ZP730-2 fully meets the sensitivity requirements of European Standard, EN 54 Pt 7 and is approved by several international approval bodies.

Automatic self test

False and unwanted alarms are virtually eliminated - smoke levels are continuously sensed by the unit and transmitted via the ZP wiring loop as electronic signals, which are assessed and verified by the control panel prior to any alarm decision being taken.

Installed as part of the ZP3 analogue addressable system, up to 127 sensing devices can be connected to each of the control panel loops. All loop devices incorporate switch settings enabling them to be assigned a unique address, which is polled by the panel every two seconds.

Sensor sensitivity, calibration and self-test are carried out automatically by the ZP3 system. Removal or replacement of an incorrect sensing device, will be identified by the system and shown as a fault. Sophisticated auto contamination adjustment, compensates for any drift in performance due to dirt in the sensing chamber.

Locking base option

For ease of removal sensors plug into a range of base units by a simple twist and lock action. A site selectable option is provided to lock the sensor into its base. Once applied the unit can only be removed by means of a special tool.

A red LED indicator situated on the sensor moulding flashes to indicate when the unit is in alarm. Space for address labels is provided on sensor and base mouldings, ensuring units are replaced in their correct location and address numbers can be identified from floor level.



Standard Features

- Responds to slow burning fires
- Complies to EN 54 Pt7
- Analogue sensing - reduces false and unwanted alarms
- Addressable - system knows the status and location of every sensor
- Alarm verification, self test, auto contamination adjustment

ZP730-2

Analogue optical smoke sensor

Specifications

Model No	ZP730-2
Specification	EN54 Pt7
Description	Analogue optical smoke sensor
Sensitivity	2.3% OBS / meter
Compatibility	All ZP analogue systems
Mounting	Plugs into surface or semi recessed base
Area coverage	100m ² subject to local codes
Wiring	2 core loop or spur
Monitoring	Open and short circuit fault. Sensor removal and device type
Indication	Alarm LED (red)
Operating voltage	Address line pulsed 20V (19.5V to 20.5V). Max line less 4V
Current	600uA quiecent, 700uA alarm
Addressing method	7 way DIL switches in head
Detection principle	Photo electric light scatter
Application	Indoor installation
EN60529 rating	IP32
Temperature range	-10°C to +75°C
Humidity range	20% to 95% RH (non condensing)
EMC	CE marked (EEC89/336)
Material	Moulded ABS
Dimensions	106mm (dia) x 52mm (h) (excluding base)
Height	60mm ZP7-SB1 surface base, 38mm ZP7-RB1 recessed base
Colour	White
Weight	105g (excluding) base)
Publication No	PS1244

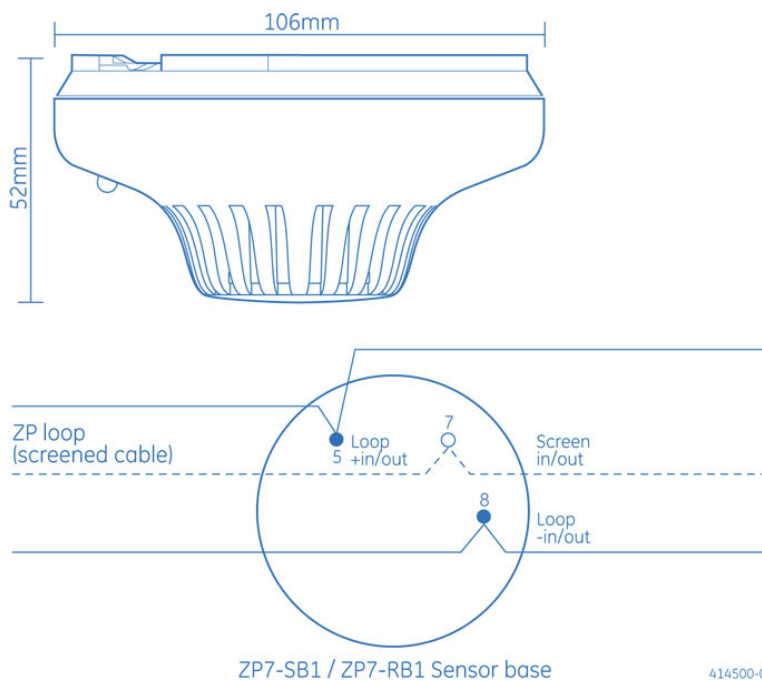

Ordering Information

Part No.	Description
ZP730-2	Analogue optical smoke sensor

As a company of innovation, GE Security reserves the right to change product specifications without notice. For the latest product specifications, visit GE Security online or contact your GE Security sales representative.

IPS-ZP730-2-2007-07-31 10:54:41 Released : 12.07.2007

UK Sales: 8 Newmarket Court, Chippenham Drive, Kingston, Milton Keynes, MK10 0AQ, United Kingdom, Telephone +44 (0) 1908 281981, Fax +44 (0) 1908 282554
South Africa: Zitton House, 555 Voortrekker Road, Maitland, 7405, P.O. Box 181, Maitland, 7404, South Africa, Telephone +27 (0)21 506 6000, Fax +27 (0)21 506 6050